

Tehničko crtanje – vježbanje i ponavljanje

Zadatci za vježbu:

- Crtanje plašteva geometrijskih tijela
- Kotiranje
- Pravokutno projiciranje

Riješiti radne listove RL-3.3.2 i 3.3.3

Zadatak 1

Nacrtati plašt četverostrane piramide.

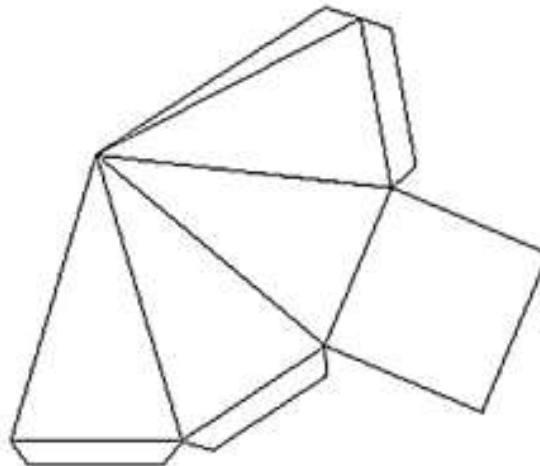
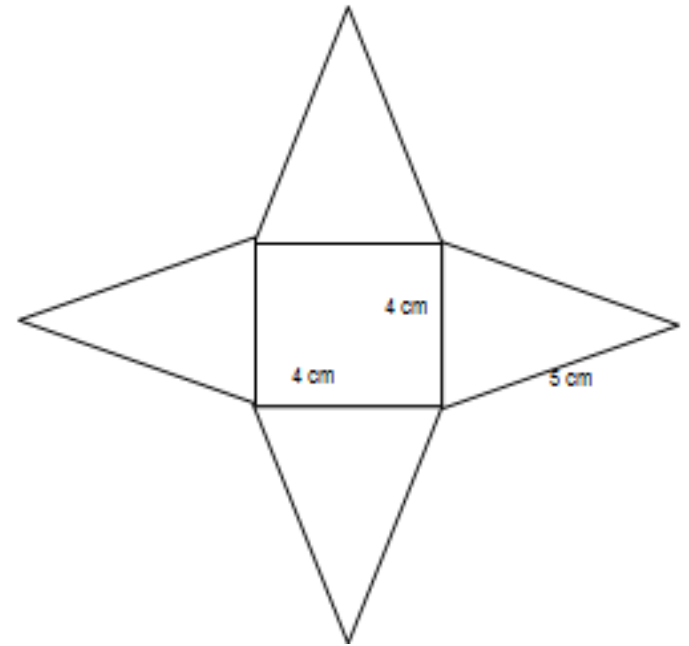
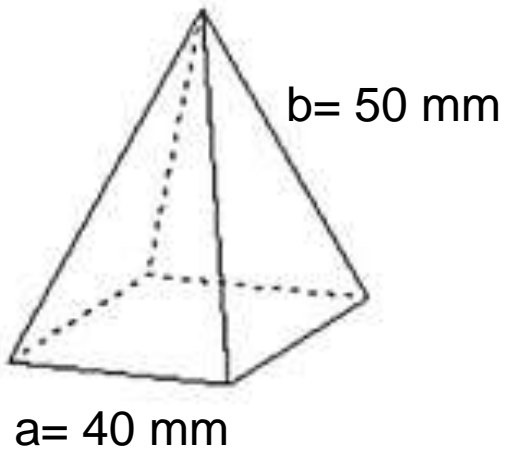

Zadatak 2

Nacrt tehničke tvorevine nacrtan je u prirodnom mjerilu.
Primjeni pravila tehničkog crtanja i kotiraj crtež.

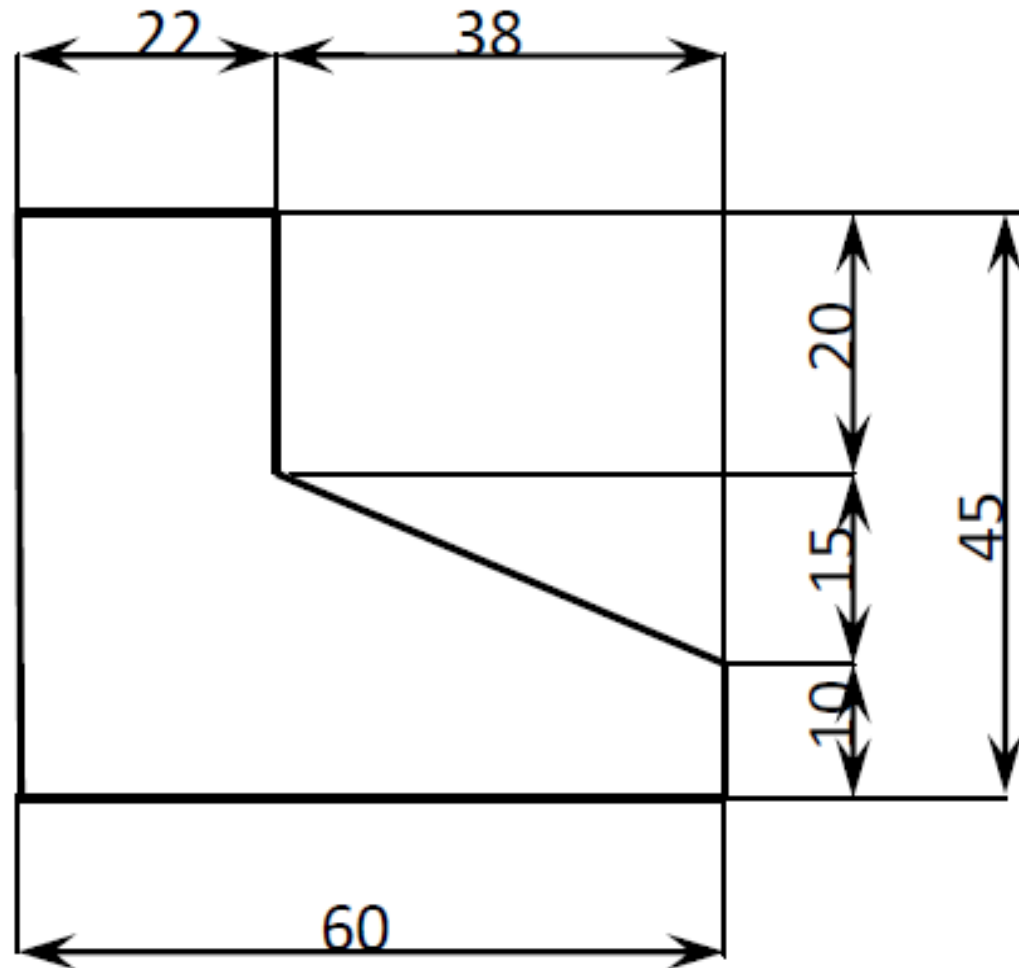
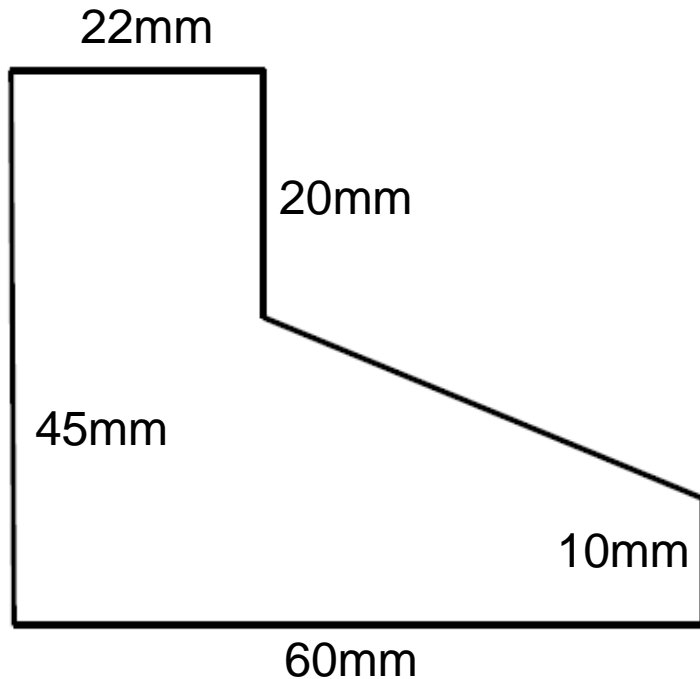

Zadatak 3

Nacrtati plašt trostrane piramide.

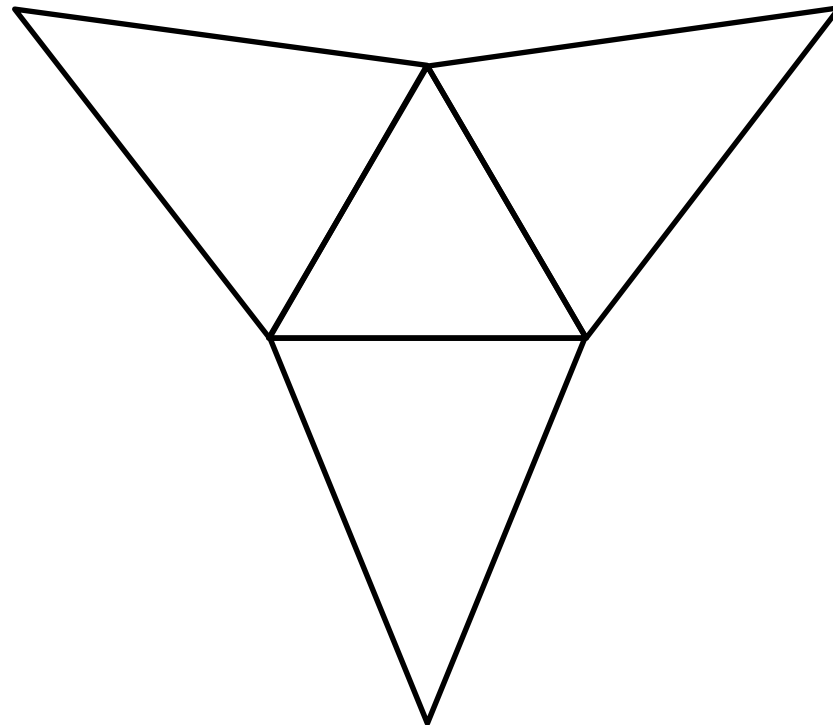
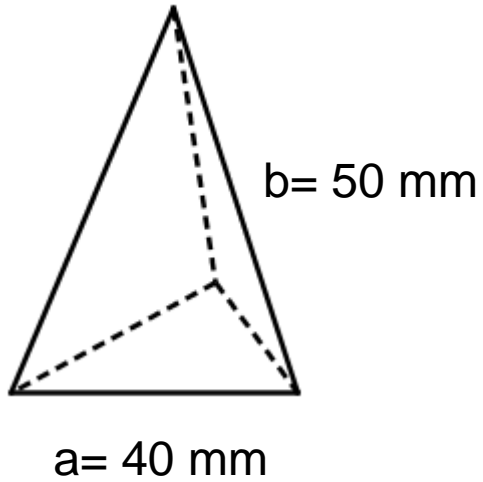

Zadatak 4

Nacrtaj koristeći pribor za tehničko crtanje pravokutne projekcije (nacrt, bokocrt i tlocrt) tijela prikazanog crtežom u prostornoj projekciji.

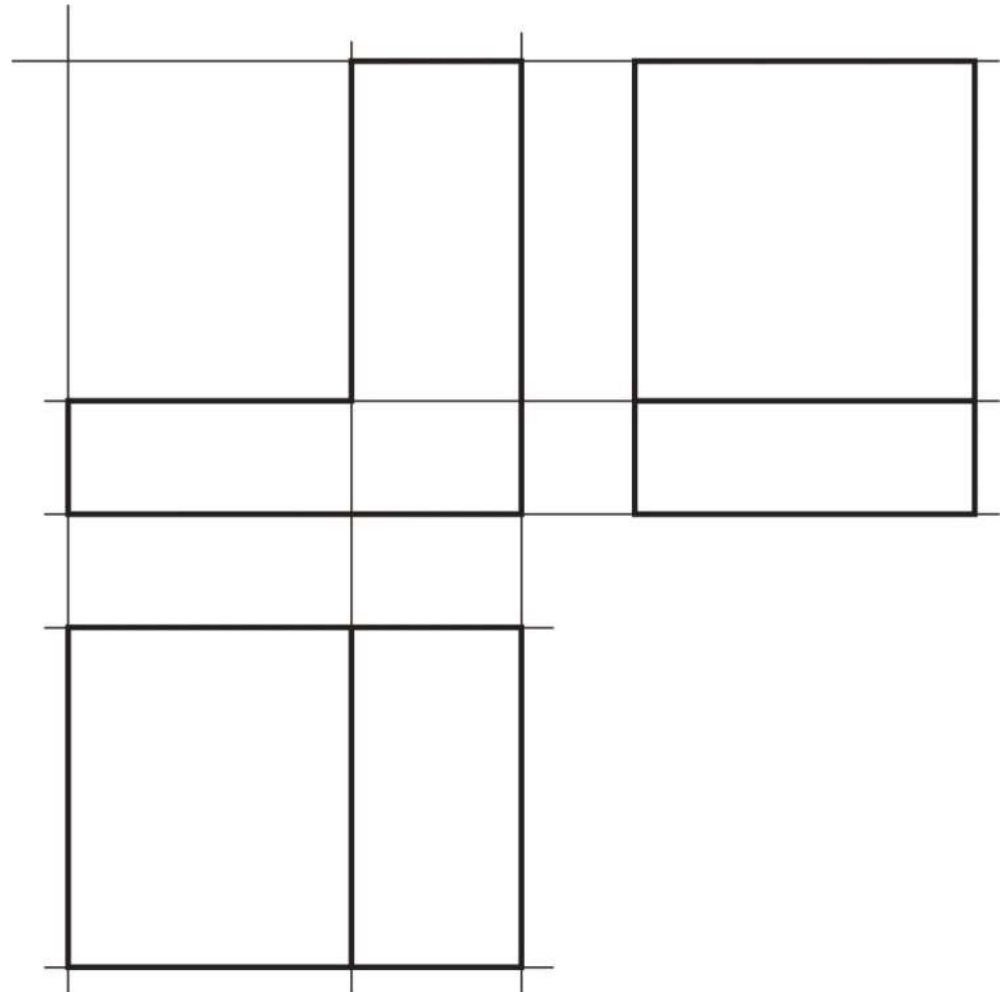
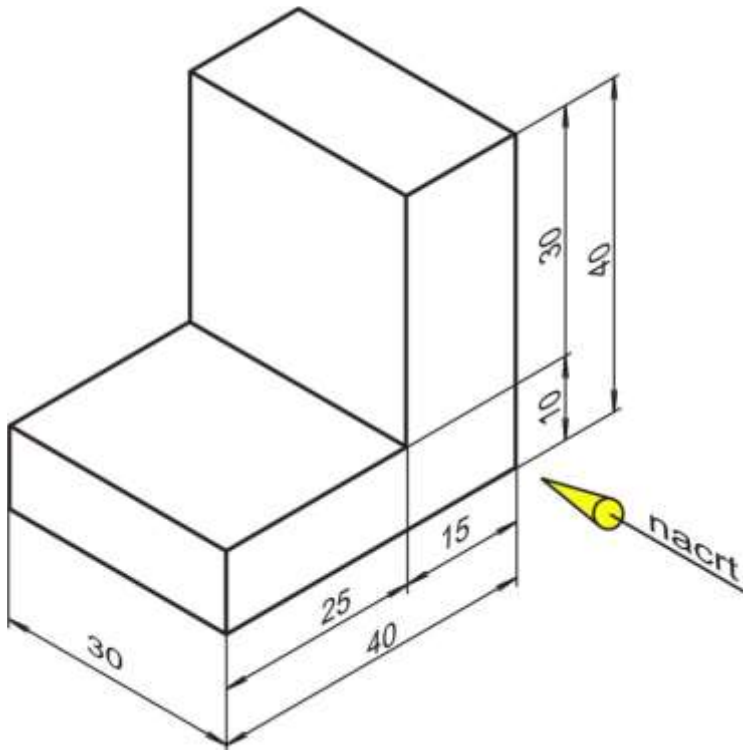

Zadatak 5

Skiciraj nacrt i bokocrt valjka.

$a = 60\text{mm}$, $r = 20\text{mm}$

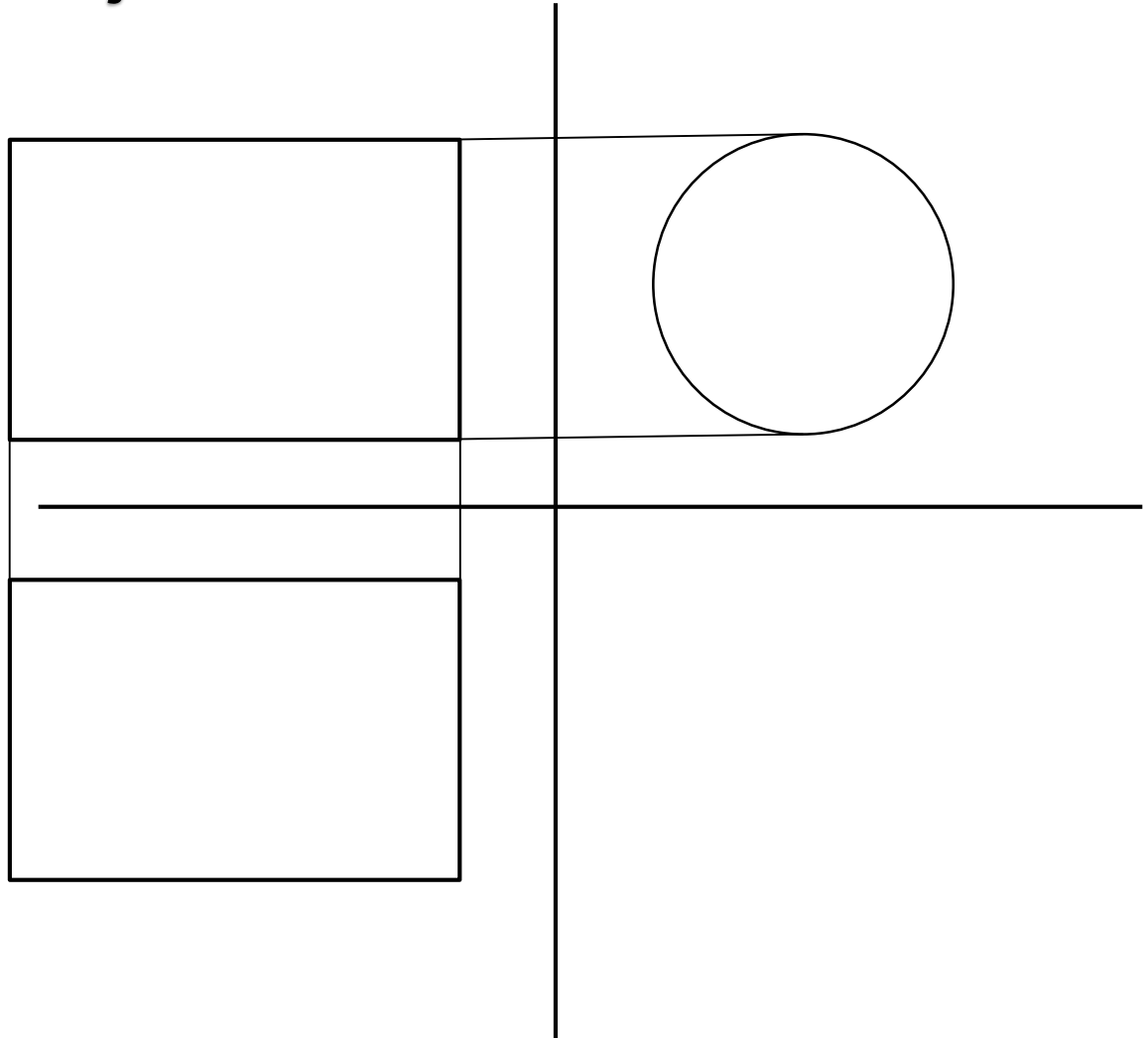
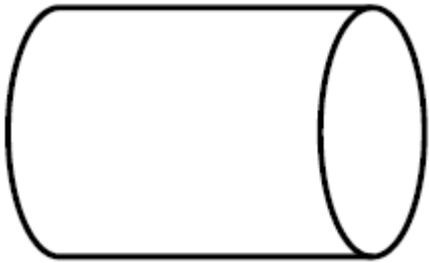

Zadatak 6

Prema prostornom crtežu složenih geometrijskih tijela i zadanom pogledu **skicirajte** njihove pravokutne projekcije.

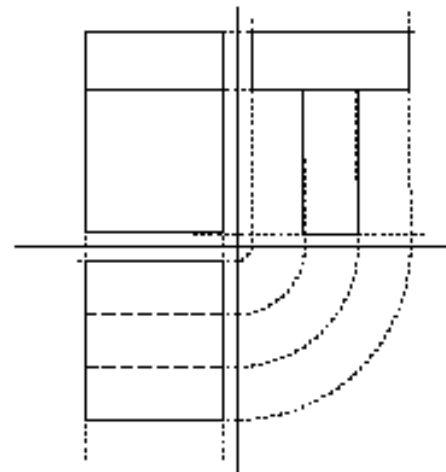
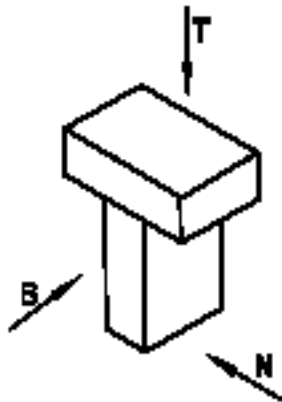
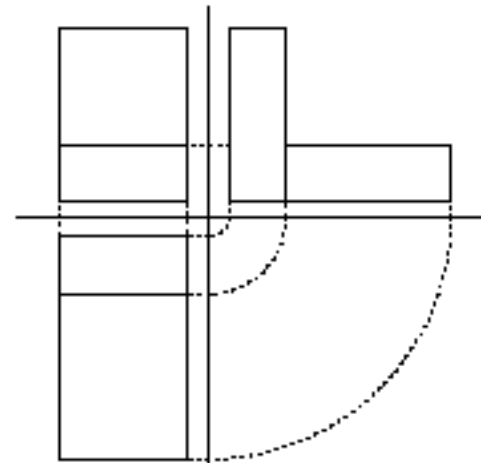
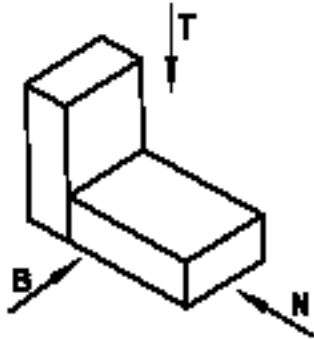

ZA ONE KOJI ŽELE ZNATI VIŠE

